

This Page Is Inserted by IFW Operations  
and is not a part of the Official Record

## **BEST AVAILABLE IMAGES**

Defective images within this document are accurate representations of the original documents submitted by the applicant.

Defects in the images may include (but are not limited to):

- BLACK BORDERS
- TEXT CUT OFF AT TOP, BOTTOM OR SIDES
- FADED TEXT
- ILLEGIBLE TEXT
- SKEWED/SLANTED IMAGES
- COLORED PHOTOS
- BLACK OR VERY BLACK AND WHITE DARK PHOTOS
- GRAY SCALE DOCUMENTS

IMAGES ARE BEST AVAILABLE COPY.

**As rescanning documents *will not* correct images,  
please do not report the images to the  
Image Problems Mailbox.**



INTERNATIONAL APPLICATION PUBLISHED UNDER THE PATENT COOPERATION TREATY (PCT)

<p>(51) International Patent Classification <sup>7</sup> : <b>G06F 11/14</b></p>	<p><b>A1</b></p>	<p>(11) International Publication Number: <b>WO 00/11553</b> (43) International Publication Date: <b>2 March 2000 (02.03.00)</b></p>
<p>(21) International Application Number: <b>PCT/US99/17137</b> (22) International Filing Date: <b>28 July 1999 (28.07.99)</b> (30) Priority Data: <b>09/139,257</b>      <b>25 August 1998 (25.08.98)</b>      <b>US</b> (71) Applicant: <b>NETWORK APPLIANCE, INC. [US/US]; 2770 San Tomas Expressway, Santa Clara, CA 95051 (US).</b> (72) Inventors: <b>SCHOENTHAL, Scott; 23 Westside Court, San Ramon, CA 94583 (US). ROWE, Alan; 6443 Curie Court, San Jose, CA 95123 (US). KLEIMAN, Steven; 157 El Monte Court, Los Altos, CA 94022 (US).</b> (74) Agent: <b>SWERNOFSKY LAW GROUP; P.O. Box 390013, Mountain View, CA 94039-0013 (US).</b></p>	<p>(81) Designated States: <b>CA, CN, JP, KR, European patent (AT, BE, CH, CY, DE, DK, ES, FI, FR, GB, GR, IE, IT, LU, MC, NL, PT, SE).</b>  <b>Published</b> <i>With international search report.</i></p> <p style="text-align: center; font-size: 2em; font-weight: bold;">RECEIVED</p> <p style="text-align: center;">SWERNOFSKY LAW GROUP</p>	

(54) Title: **COORDINATING PERSISTENT STATUS INFORMATION WITH MULTIPLE FILE SERVERS**

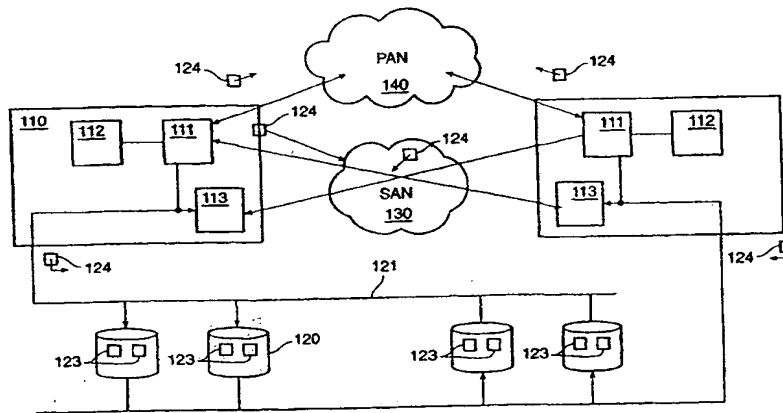

(57) Abstract

The invention provides a storage system, and a method for operating a storage system, that provides for relatively rapid and reliable takeover among a plurality of independent file servers. Each file server maintains a reliable communication path to the others. Each file server maintains its own state in reliable memory. Each file server regularly confirms the state of the other file servers. Each file server labels messages on the redundant communication paths, so as to allow other file servers to combine the redundant communication paths into a single ordered stream of messages. Each file server maintains its own state in its persistent memory and compares that state with the ordered stream of messages, so as to determine whether other file servers have progressed beyond the file server's own last known state. Each file server uses the shared resources (such as magnetic disks) themselves as part of the redundant communication paths, so as to prevent mutual attempts at takeover of resources when each file server believes the other to have failed. Each file server provides a status report to the others when recovering from an error, so as to prevent the possibility of multiple file servers each repeatedly failing and attempting to seize the resources of the others.

**FOR THE PURPOSES OF INFORMATION ONLY**

Codes used to identify States party to the PCT on the front pages of pamphlets publishing international applications under the PCT.

AL	Albania	ES	Spain	LS	Lesotho	SI	Slovenia
AM	Armenia	FI	Finland	LT	Lithuania	SK	Slovakia
AT	Austria	FR	France	LU	Luxembourg	SN	Senegal
AU	Australia	GA	Gabon	LV	Latvia	SZ	Swaziland
AZ	Azerbaijan	GB	United Kingdom	MC	Monaco	TD	Chad
BA	Bosnia and Herzegovina	GE	Georgia	MD	Republic of Moldova	TG	Togo
BB	Barbados	GH	Ghana	MG	Madagascar	TJ	Tajikistan
BE	Belgium	GN	Guinea	MK	The former Yugoslav Republic of Macedonia	TM	Turkmenistan
BF	Burkina Faso	GR	Greece			TR	Turkey
BG	Bulgaria	HU	Hungary	ML	Mali	TT	Trinidad and Tobago
BJ	Benin	IE	Ireland	MN	Mongolia	UA	Ukraine
BR	Brazil	IL	Israel	MR	Mauritania	UG	Uganda
BY	Belarus	IS	Iceland	MW	Malawi	US	United States of America
CA	Canada	IT	Italy	MX	Mexico	UZ	Uzbekistan
CF	Central African Republic	JP	Japan	NE	Niger	VN	Viet Nam
CG	Congo	KE	Kenya	NL	Netherlands	YU	Yugoslavia
CH	Switzerland	KG	Kyrgyzstan	NO	Norway	ZW	Zimbabwe
CI	Côte d'Ivoire	KP	Democratic People's Republic of Korea	NZ	New Zealand		
CM	Cameroon		Republic of Korea	PL	Poland		
CN	China	KR	Republic of Korea	PT	Portugal		
CU	Cuba	KZ	Kazakstan	RO	Romania		
CZ	Czech Republic	LC	Saint Lucia	RU	Russian Federation		
DE	Germany	LI	Liechtenstein	SD	Sudan		
DK	Denmark	LK	Sri Lanka	SE	Sweden		
EE	Estonia	LR	Liberia	SG	Singapore		

Title of the Invention

Coordinating Persistent Status Information with Multiple File Servers

5

Background of the Invention

1. *Field of the Invention*

10                   The invention relates to computer systems.

2. *Related Art*

15                   Computer storage systems are used to record and retrieve data. It is desirable for the services and data provided by the storage system to be available for service to the greatest degree possible. Accordingly, some computer storage systems provide a plurality of file servers, with the property that when a first file server fails, a second file server is available to provide the services and the data otherwise provided by the first. The second file server provides these services and data by takeover of resources  
20 otherwise managed by the first file server.

                  One problem in the known art is that when two file servers each provide backup for the other, it is important that each of the two file servers is able to reliably detect failure of the other and to smoothly handle any required takeover operations. It  
25 would be advantageous for this to occur without either of the two file servers interfering with proper operation of the other. This problem is particularly acute in systems when one or both file servers recover from a service interruption.

                  Accordingly, it would be advantageous to provide a storage system and a  
30 method for operating a storage system, that provides for relatively rapid and reliable takeover among a plurality of independent file servers. This advantage is achieved in an embodiment of the invention in which each file server (a) maintains redundant

communication paths to the others, (b) maintains its own state in persistent memory at least some of which is accessible to the others, and (c) regularly confirms the state of the other file servers.

5

### Summary of the Invention

The invention provides a storage system and a method for operating a storage system, that provides for relatively rapid and reliable takeover among a plurality of independent file servers. Each file server maintains a reliable (such as redundant) communication path to the others, preventing any single point of failure in communication among file servers. Each file server maintains its own state in reliable (such as persistent) memory at least some of which is accessible to the others, providing a method for confirming that its own state information is up to date, and for reconstructing proper state information if not. Each file server regularly confirms the state of the other file servers, and attempts takeover operations only when the other file servers are clearly unable to provide their share of services.

In a preferred embodiment, each file server sequences messages on the redundant communication paths, so as to allow other file servers to combine the redundant communication paths into a single ordered stream of messages. Each file server maintains its own state in its persistent memory and compares that state with the ordered stream of messages, so as to determine whether other file servers have progressed beyond the file server's own last known state. Each file server uses the shared resources (such as magnetic disks) themselves as part of the redundant communication paths, so as to prevent mutual attempts at takeover of resources when each file server believes the other to have failed.

In a preferred embodiment, each file server provides a status report to the others when recovering from an error, so as to prevent the possibility of multiple file servers each repeatedly failing and attempting to seize the resources of the others.

### Brief Description of the Drawings

Figure 1 shows a block diagram of a multiple file server system with coordinated persistent status information.

5

Figure 2 shows a state diagram of a method of operation for a multiple file server system with coordinated persistent status information.

### Detailed Description of the Preferred Embodiment

10

In the following description, a preferred embodiment of the invention is described with regard to preferred process steps and data structures. However, those skilled in the art would recognize, after perusal of this application, that embodiments of the invention may be implemented using one or more general purpose processors (or  
15 special purpose processors adapted to the particular process steps and data structures) operating under program control, and that implementation of the preferred process steps and data structures described herein using such equipment would not require undue experimentation or further invention.

20

In a preferred embodiment, the file server system, and each file server therein, operates using inventions described in the following patent applications:

- o Application Serial No. 09/037,652, filed March 10, 1998, in the name of inventor Steven Kleiman, titled "Highly Available File Servers," attorney docket number  
25 NAP-012.

Each of these applications is hereby incorporated by reference as if fully set forth herein. They are collectively referred to as the "Clustering Disclosures."

30

In a preferred embodiment, each file server in the file server system controls its associated mass storage devices so as to form a redundant array, such as a RAID storage system, using inventions described in the following patent applications:

- o Application Serial No. 08/471,218, filed June 5, 1995, in the name of inventors David Hitz et al., titled "A Method for Providing Parity in a Raid Sub-System Using Non-Volatile Memory", attorney docket number NET-004;
- 5 o Application Serial No. 08/454,921, filed May 31, 1995, in the name of inventors David Hitz et al., titled "Write Anywhere File-System Layout", attorney docket number NET-005;
- 10 o Application Serial No. 08/464,591, filed May 31, 1995, in the name of inventors David Hitz et al., titled "Method for Allocating Files in a File System Integrated with a Raid Disk Sub-System", attorney docket number NET-006.

Each of these applications is hereby incorporated by reference as if fully set forth herein. They are collectively referred to as the "WAFL Disclosures."

15

### *System Elements*

Figure 1 shows a block diagram of a multiple file server system with coordinated persistent status information.

20

A system 100 includes a plurality of file servers 110, a plurality of mass storage devices 120, a SAN (system area network) 130, and a PN (public network) 140.

25 In a preferred embodiment, there are exactly two file servers 110. Each file server 110 is capable of acting independently with regard to the mass storage devices 120. Each file server 110 is disposed for receiving file server requests from client devices (not shown), for performing operations on the mass storage devices 120 in response thereto, and for transmitting responses to the file server requests to the client devices.

30

For example, in a preferred embodiment, the file servers 110 are each similar to file servers described in the Clustering Disclosures.

Each of the file servers 110 includes a processor 111, program and data memory 112, and a persistent memory 113 for maintaining state information across possible service interruptions. In a preferred embodiment, the persistent memory 113 includes a nonvolatile RAM.

5

The mass storage devices 120 preferably include a plurality of writeable magnetic disks, magneto-optical disks, or optical disks. In a preferred embodiment, the mass storage devices 120 are disposed in a RAID configuration or other system for maintaining information persistent across possible service interruptions.

10

Each of the mass storage devices 120 are coupled to each of the file servers 110 using a mass storage bus 121. In a preferred embodiment, each file server 110 has its own mass storage bus 121. The first file server 110 is coupled to the mass storage devices 120 so as to be a primary controller for a first subset of the mass storage devices 120 and a secondary controller for a second subset thereof. The second file server 110 is coupled to the mass storage devices 120 so as to be a primary controller for the second subset of the mass storage devices 120 and a secondary controller for the first subset thereof.

15

The mass storage bus 121 associated with each file server 110 is coupled to the processor 111 for that file server 110 so that file server 110 can control mass storage devices 120. In alternative embodiments, the file servers 110 may be coupled to the mass storage devices 120 using other techniques, such as fiber channel switches or switched fabrics.

20

25

The mass storage devices 120 are disposed to include a plurality of mailbox disks 122, each of which has at least one designated region 123 into which one file server 110 can write messages 124 for reading by the other file server 110. In a preferred embodiment, there is at least one designated region 123, on each mailbox disk 122 for reading and at least one designated region 123 for writing, by each file server 110.

30



The SAN 130 is coupled to the processor 111 and to the persistent memory 113 at each of the file servers 110. The SAN 130 is disposed to transmit messages 124 from the processor 111 at the first file server 110 to the persistent memory 113 at the second file server 110. Similarly, the SAN 130 is disposed to transmit messages 124 from the processor 111 at the second file server 110 to the persistent memory 113 at the first file server 110.

In a preferred embodiment, the SAN 130 comprises a ServerNet connection between the two file servers 110. In alternative embodiments, the persistent memory 112 may be disposed logically remote to the file servers 110 and accessible using the SAN 130.

The PN 140 is coupled to the processor 111 at each of the file servers 110. The PN 140 is disposed to transmit messages 124 from each file server 110 to the other file server 110.

In a preferred embodiment, the PN 140 can comprise a direct communication channel, a LAN (local area network), a WAN (wide area network), or some combination thereof.

20

Although the mass storage devices 120, the SAN 130, and the PN 140 are each disposed to transmit messages 124, the messages 124 transmitted using each of these pathways between the file servers 110 can have substantially differing formats, even though payload for those messages 124 is identical.

25

### *Method of Operation*

Figure 2 shows a state diagram of a method of operation for a multiple file server system with coordinated persistent status information.

30

A state diagram 200 includes a plurality of states and a plurality of transitions there between. Each transition is from a first state to a second state and occurs upon detection of a selected event.

5 The state diagram 200 is followed by each of the file servers 110 independently. Thus, there is a state for "this" file server 110 and another (possibly same, possibly different) state for the "the other" file server 110. Each file server 110 independently determines what transition to follow from each state to its own next state. The state diagram 200 is described herein with regard to "this" file server 110.

10 In a NORMAL state 210, this file server 110 has control of its own assigned mass storage devices 120.

15 In a TAKEOVER state 220, this file server 110 has taken over control of the mass storage devices 120 normally assigned to the other file server 110.

In a STOPPED state 230, this file server 110 has control of none of the mass storage devices 120 and is not operational.

20 In a REBOOTING state 240, this file server 110 has control of none of the mass storage devices 120 and is recovering from a service interruption.

#### NORMAL State

25 In the NORMAL state 210, both file servers 110 are operating properly, and each controls its set of mass storage devices 120.

30 In this state, each file server 110 periodically sends state information in messages 124 using the redundant communication paths between the two file servers 110. Thus, each file server 110 periodically transmits messages 124 having state information by the following techniques:

- o Each file server 110 transmits a message 124 by copying that message to the mailbox disks on its assigned mass storage devices 120.

5 In a preferred embodiment, messages 124 are transmitted using the mailbox disks by writing the messages 124 to a first mailbox disk and then to a second mailbox disk.

- o Each file server 110 transmits a message 124 by copying that message 124, using the SAN 130, to its persistent memory 113 (possibly both its own persistent memory 113 and that for the other file server 110).

In a preferred embodiment, messages 124 are transmitted using the SAN 130 using a NUMA technique.

15 and

- o Each file server 110 transmits a message 124 by transmitting that message 124, using the PN 140, to the other file server 110.

20 In a preferred embodiment, messages 124 are transmitted using the PN 140 using encapsulation in a communication protocol known to both file servers 110, such as UDP or IP.

Each message 124 includes the following information for "this" file server 110 (that is, the file server 110 transmitting the message 124):

25

- o a system ID for this file server 110;
- o a state indicator for this file server 110;

30

In a preferred embodiment, the state indicator can be one of the following:

(NORMAL) operating normally,

(TAKEOVER) this file server 110 has taken over control of the mass storage devices 120,

(NO-TAKEOVER) this file server 110 does not want the receiving file server to take over control of its mass storage devices 120, and

(DISABLE) takeover is disabled for both file servers 110.

- o a generation number  $G_i$ , comprising a monotonically increasing number identified with a current instantiation of this file server 110;

In a preferred embodiment, the instantiation of this file server 110 is incremented when this file server 110 is initiated on boot-up. If any file server 110 suffers a service interruption that involves reinitialization, the generation number  $G_i$  will be incremented, and the message 124 will indicate that it is subsequent to any message 124 send before the service interruption.

and

- o a sequence number  $S_i$ , comprising a monotonically increasing number identified with the current message 124 transmitted by this file server 110.

Similarly, each message 124 includes the following information for "the other" file server 110 (that is, the file server 110 receiving the message 124):

- o a generation number  $G_i$ , comprising a monotonically increasing number identified with a current instantiation of the other file server 110;

and

- o a sequence number  $S_i$ , comprising a monotonically increasing number identified with the most recent message 124 received from the other file server 110.

Each message 124 also includes a version number of the status protocol with which the message 124 is transmitted.

Since the file server 110 receives the messages 124 using a plurality of pathways, it determines for each message 124 whether or not that message 124 is "new" (the file server 110 has not seen it before), or "old" (the file server 110 has seen it before). The file server 110 maintains a record of the generation number  $G_i$  and the sequence number  $S_i$  of the most recent new message 124. The file server 110 determines that the particular message 124 is new if and only if:

o its generation number  $G_i$  is greater than the most recent new message 124;

or

o its generation number  $G_i$  is equal to the most recent new message 124 and its sequence number  $S_i$  is greater than most recent new message 124.

If either of the file servers 110 determines that the message 124 is not new, that file server 110 can ignore that message 124.

In this state, each file server 110 periodically saves its own state information using the messages 124. Thus, each file server 110 records its state information both on its own mailbox disks and in its own persistent memory 113.

In this state, each file server 110 periodically watches for a state change in the other file server 110. The first file server 110 detects a state change in the second file server 110 in one of at least two ways:

o The first file server 110 notes that the second file server 110 has not updated its state information (using a message 124) for a timeout period.

In a preferred embodiment, this timeout period is two-half seconds for communication using the mailbox disks and one-half second for communication

using the SAN 130. However, there is no particular requirement for using these timeout values; in alternative embodiments, different timeout values or techniques other than timeout periods may be used.

5 and

o The first file server 110 notes that the second file server 110 has updated its state information (using one or more messages 124) to indicate that the second file server 110 has changed its state.

10 In a preferred embodiment, the second file server 110 indicates when it is in one of the states described with regard to each message 124.

If the first file server 110 determines that the second file server 110 is also in the NORMAL state, the NORMAL-OPERATION transition 211 is taken to remain in  
15 the state 210.

The first file server 110 makes its determination responsive to messages 124 it receives from the second file server 110. If there are no such messages 124 for a time period responsive to the timeout period described above (such as two to five times  
20 the timeout period), the first file server 110 decides that the second file server 110 has suffered a service interruption.

If the first file server 110 determines that the second file server 110 has suffered a service interruption (that is, the second file server 110 is in the STOPPED state  
25 230), the TAKEOVER-OPERATION transition 212 is taken to enter the TAKEOVER state 220.

The TAKEOVER-OPERATION transition 212 can be disabled by a message 124 state indicator such as DISABLE or NO-TAKEOVER.  
30

In a preferred embodiment, either file server 110 can disable the TAKEOVER-OPERATION transition 212 responsive to (a) an operator command, (b) a

synchronization error between the persistent memories 113, or (c) any compatibility mismatch between the file servers 110.

To perform the TAKEOVER-OPERATION transition 212, this file server  
5 110 performs the following actions at a step 213:

- o This file server 110 sends the message 124 state indicator TAKEOVER to the other file server 110, using including the reliable communication path (including the mailbox disks 122, the SAN 130, and the PN 140).
- 10 o This file server 110 waits for the other file server 110 to have the opportunity to receive and act on the TAKEOVER-OPERATION transition 212 (that is, to suspend its own access to the mass storage devices 120).
- 15 o This file server 110 issues disk reservation commands to the mass storage devices 120 normally assigned to the other file server 110.
- o This file server 110 takes any other appropriate action to assure that the other file server 110 is passive.

20 If the takeover operation is successful, the TAKEOVER-OPERATION transition 212 completes and this file server enters the TAKEOVER state 220. Otherwise (such as if takeover is disabled), this file server 110 returns to the NORMAL state 210.

### 25 TAKEOVER State

In the TAKEOVER state 220, this file server 110 is operating properly, but the other file server 110 is not. This file server 110 has taken over control of both its and  
30 the other's mass storage devices 120.

In this state, this file server 110 continues to write messages 124 to the persistent memory 113 and to the mailbox disks 122, so as to preserve its own state in the event of a service interruption.

5 In this state, this file server 110 continues to control all the mass storage devices 120, both its own and those normally assigned to the other file server 110, until this file server 110 determines that it should give back control of some mass storage devices 120.

10 In a preferred embodiment, the first file server 110 makes its determination responsive to operator control. An operator for this file server 110 determines that the other file server 110 has recovered from its service interruption. The GIVEBACK-OPERATION transition 221 is taken to enter the NORMAL state 210.

15 In alternative embodiments, the first file server 110 may make its determination responsive to messages 124 it receives from the second file server 110. If the second file server 110 sends messages 124 indicating that it has recovered from a service interruption (that is, it is in the REBOOTING state 240), the first file server 110 may initiate the GIVEBACK-OPERATION transition 221.

20

To perform the GIVEBACK-OPERATION transition 221, this file server 110 performs the following actions at a step 222:

- o This file server 110 releases its disk reservation commands to the mass storage  
25 devices 120 normally assigned to the other file server 110.
- o This file server 110 sends the message 124 state indicator NORMAL to the other  
file server 110, including using the mailbox disks 122, the SAN 130, and the PN  
140.
- o This file server 110 disables the TAKEOVER-OPERATION transition 212 by the  
30 other file server 110 until the other file server 110 enters the NORMAL state 210.



This file server 110 remains at the step 222 until the other file server 110 enters the NORMAL state 210.

When the giveback operation is successful, the GIVEBACK-OPERATION transition 221 completes and this file server enters the NORMAL state 210.

### STOPPED State

In the STOPPED state 230, this file server 110 has control of none of the mass storage devices 120 and is not operational.

In this state, this file server 110 performs no operations, until this file server 110 determines that it reboot.

In a preferred embodiment, the first file server 110 makes its determination responsive to operator control. An operator for this file server 110 determines that it has recovered from its service interruption. The REBOOT-OPERATION transition 231 is taken to enter the REBOOTING state 240.

In alternative embodiments, the first file server 110 may make its determination responsive to a timer or other automatic attempt to reboot. When this file server 110 determines that it has recovered from its service interruption, it attempts to reboot, and the REBOOT-OPERATION transition 231 is taken to enter the REBOOTING state 240.

### REBOOTING State

In the REBOOTING state 240, this file server 110 has control of none of the mass storage devices 120 and is recovering from a service interruption.

In this state, the file server 110 attempts to recover from a service interruption.

If this file server 110 is unable to recover from the service interruption, the REBOOT-FAILED transition 241 is taken and this file server 110 remains in the REBOOTING state 240.

5 If this file server 110 is able to recover from the service interruption, but the other file server 110 is in the TAKEOVER state 220, the REBOOT-FAILED transition 241 is taken and this file server 110 remains in the REBOOTING state 240. In this case, the other file server 110 controls the mass storage devices 120 normally assigned to this file server 110, and this file server 110 waits for the GIVEBACK-  
10 OPERATION transition 221 before re-attempting to recover from the service interruption.

If this file server 110 is able to recover from the service interruption, and determines it should enter the NORMAL state 210 (as described below), the REBOOT-  
15 NORMAL transition 242 is taken and this file server 110 enters the NORMAL state 210.

If this file server 110 is able to recover from the service interruption, and determines it should enter the TAKEOVER state 210 (as described below), the REBOOT- TAKEOVER transition 243 is taken and this file server 110 enters the  
20 TAKEOVER state 210.

In a preferred embodiment, this file server 110 performs the attempt to recover from the service interruption with the following steps.

25 At a step 251, this file server 110 initiates its recovery operation.

At a step 252, this file server 110 determines whether it is able to write to any of the mass storage devices 120 (that is, if the other file server 110 is in the TAKEOVER state 220). If so, this file server 110 displays a prompt to an operator so  
30 indicating and requesting the operator to command the other file server 110 to perform the GIVEBACK-OPERATION transition 221.

This file server 110 waits until the operator commands the other file server 110 to perform a giveback operation, waits until the GIVEBACK-OPERATION transition 221 is complete, and proceeds with the next step.

5           At a step 253, this file server 110 determines the state of the other file server 110. This file server 110 makes this determination in response to its own persistent memory 113 and the mailbox disks 122. This file server 110 notes the state it was in before entering the REBOOTING state 240 (that is, either the NORMAL state 210 or the TAKEOVER state 220).

10           If this file server 110 determines that the other file server 110 is in the NORMAL state 210, it proceeds with the step 254. If this file server 110 determines that it had previously taken over all the mass storage devices 120 (that is, that the other file server 110 is in the STOPPED state 230 or the REBOOTING state 240), it proceeds with  
15 the step 255.

          At a step 254, this file server 110 attempts to seize its own mass storage devices 120 but not those normally assigned to the other file server 110. This file server 110 proceeds with the step 256.

20           At a step 255, this file server 110 attempts to seize both its own mass storage devices 120 and those normally assigned to the other file server 110. This file server 110 proceeds with the step 256.

25           At a step 256, this file server 110 determines whether its persistent memory 113 is current with regard to pending file server operations. If not, this file server 110 flushes its persistent memory 113 of pending file server operations.

30           At a step 257, this file server 110 determines if it is able to communicate with the other file server and if there is anything (such as an operator command) preventing takeover operations. This file server 110 makes its determination in response to the persistent memory 113 and the mailbox disks 122.

At a step 258, if this file server 110 was in the NORMAL state 210 before entering the REBOOTING state 240 (that is, this file server 110 performed the step 254 and seized only its own mass storage devices 120), it enters the NORMAL state 210.

5           At a step 258, if this file server 110 was in the TAKEOVER state 220 before entering the REBOOTING state 240 (that is, this file server 110 performed the step 255 and seized all the mass storage devices 120, it enters the TAKEOVER state 220.

*Alternative Embodiments*

10

Although preferred embodiments are disclosed herein, many variations are possible which remain within the concept, scope, and spirit of the invention, and these variations would become clear to those skilled in the art after perusal of this application.

Claims

1. A file server including  
a set of storage devices capable of being shared with a second file server;  
5 a controller disposed for coupling to said shared set of storage devices;  
a transceiver disposed for coupling to a communication path and for  
communicating messages using said communication path, said communication path  
using said shared set of storage devices to communicate said messages;  
a takeover monitor coupled to at least part of said shared set of storage  
10 devices, and responsive to said communication path and said shared set of storage  
devices.
2. A file server as in claim 1, including persistent memory storing state  
information about said file server, said takeover monitor being responsive to said  
15 persistent memory.
3. Apparatus including  
a shared resource;  
a pair of servers each coupled to said shared resource and each disposed for  
20 managing at least part of said shared resource;  
a communication path disposed for coupling a sequence of messages  
between said pair, said communication path disposed for using said shared resource for  
coupling said sequence of messages;  
each one of said pair being disposed for takeover of at least part of said  
25 shared resource in response to said communication path;  
whereby said communication path prevents both of said pair from  
concurrently performing said takeover.
4. Apparatus as in claim 3, wherein  
30 at least one said server includes a file server;  
said shared resource includes a storage medium; and

said communication path includes a designated location on said storage medium.

5           5.       Apparatus as in claim 3, wherein  
each one of said pair includes persistent memory;  
said persistent memory being disposed for storing state information about  
said pair; and  
each one of said pair being disposed for takeover in response to said  
persistent memory.

10           6.       Apparatus as in claim 3, wherein  
each said server is disposed for transmitting a message including recovery  
information relating to a status of said server on recovery from a service interruption; and  
each said server is disposed so that giveback of at least part of said shared  
15 resource is responsive to said recovery information.

            7.       Apparatus as in claim 3, wherein  
each said server is disposed for transmitting a message including recovery  
information relating to a status of said server on recovery from a service interruption; and  
20 each said server is disposed so that said takeover is responsive to said  
recovery information.

            8.       Apparatus as in claim 3, wherein  
said pair includes a first server and a second server;  
25 said first server determines a state for itself and for said second server in  
response to said communication path;  
said second server determines a state for itself and for said first server in  
response to said communication path;  
whereby said first server and said second server concurrently each  
30 determine state for each other, such that it does not occur that each of said first server and  
said second server both consider the other to be inoperative.

9. Apparatus as in claim 3, wherein  
said shared resource includes a plurality of storage devices; and  
said communication path includes at least part of said storage devices.

5 10. Apparatus as in claim 3, wherein  
said communication path includes a plurality of independent  
communication paths between said pair; and  
each message in said sequence includes a generation number, said  
generation number being responsive to a service interruption and a persistent memory for  
10 a sender of said message.

11. Apparatus as in claim 3, wherein  
said communication path includes a plurality of independent  
communication paths between said pair; and  
15 said first server is disposed for determining a state for itself and for said  
second server in response to a state of said shared resource and in response to a state of a  
persistent memory at said first server.

20 12. Apparatus as in claim 3, wherein  
said communication path includes a plurality of independent  
communication paths between said pair; and  
said plurality of independent communication paths includes at least two of  
the group: a packet network, a shared storage element, a system area network.

25 13. Apparatus as in claim 3, wherein  
said communication path is disposed for transmitting at least one message  
from a first said server to a second said server;  
said message indicating that said first server is attempting said takeover;  
receipt of said message being responsive to a state of said shared resource.

14. Apparatus as in claim 13, wherein said second server is disposed for altering its state in response to said message, in said altered state refraining from writing to said shared resource.

5 15. A method for operating a file server, said method including steps for controlling a subset of a set of shared storage devices;  
receiving and transmitting messages with a second file server, said steps for receiving and transmitting using a communication path including said shared storage devices;

10 monitoring said communicating path and said shared storage devices;  
storing state information about said file server in a persistent memory; and  
performing a takeover operation of said shared resource in response to said steps for monitoring and a state of said persistent memory.

15 16. A method including steps for managing at a first server at least a part of a shared resource;  
receiving and transmitting a sequence of messages between said first server to a second server, using said shared resource;

20 performing a takeover operation at a first server of at least part of said shared resource in response to said sequence of messages;

whereby said steps for receiving and transmitting prevent both of said first server and said second server from concurrently performing said takeover operation.

25 17. A method as in claim 16, including steps for determining, at said first server, a state for itself and for said second server in response to said communication path;

determining, at said second server, a state for itself and for said first server in response to said communication path;

30 whereby said first server and said second server concurrently each determine state for each other, such that it does not occur that each of said first server and said second server both consider the other to be inoperative.



18. A method as in claim 16, including steps for storing state information about said first server in a persistent memory, wherein said first server determines a state for itself in response to a state of said persistent memory.

5 19. A method as in claim 16, including steps for transmitting, from said first server, recovery information relating to a status of said first server on recovery from a service interruption; and performing a giveback operation of at least part of said shared resource is responsive to said recovery information.

10 20. A method as in claim 16, including steps for transmitting, from said first server, recovery information relating to a status of said server on recovery from a service interruption; wherein said steps for performing said takeover operation are responsive to  
15 said recovery information.

21. A method as in claim 16, wherein said shared resource includes a plurality of storage devices; and said communication path includes at least part of said storage devices;  
20 whereby loss of access to said part of said storage devices breaks said communication path.

22. A method as in claim 16, including steps for transmitting at least one message from a first said server to a second said  
25 server, said message indicating that said first server is attempting said takeover; altering a state of said second server in response to said message; and in said altered state refraining from writing to said shared resource.

30 23. A method as in claim 16, wherein said communication path includes a plurality of independent communication paths between said pair; and including steps for numbering said sequence of messages;

determining, at each recipient, a unified order for messages delivered using different ones of said plurality of independent communication paths; and

determining, at said first server, a state for itself and for said second server in response to a state of said shared resource and in response to a state of a persistent  
5 memory at said first server.

24. A method as in claim 16, wherein said communication path includes a plurality of independent communication paths between said pair; and including steps  
for

10 numbering said sequence of messages;  
determining, at each recipient, a unified order for messages delivered using different ones of said plurality of independent communication paths;  
transmitting substantially each message in said sequence on at least two of  
said plurality of independent communication paths, whereby there is no single point of  
15 failure for communication between said pair.

25. A method as in claim 16, wherein said communication path includes a plurality of independent communication paths between said pair; and including steps  
for

20 numbering said sequence of messages;  
determining, at each recipient, a unified order for messages delivered using different ones of said plurality of independent communication paths;  
wherein said plurality of independent communication paths includes at  
least two of the group: a packet network, a shared storage element, a system area  
25 network.

26. A method as in claim 16, wherein said communication path includes a plurality of independent communication paths between said pair; and including steps  
for

30 numbering said sequence of messages;  
determining, at each recipient, a unified order for messages delivered using different ones of said plurality of independent communication paths;

wherein said steps for numbering include (a) determining a generation number in response to a service interruption and a persistent memory for a sender of said message, and (b) providing said generation number in substantially each message in said sequence.

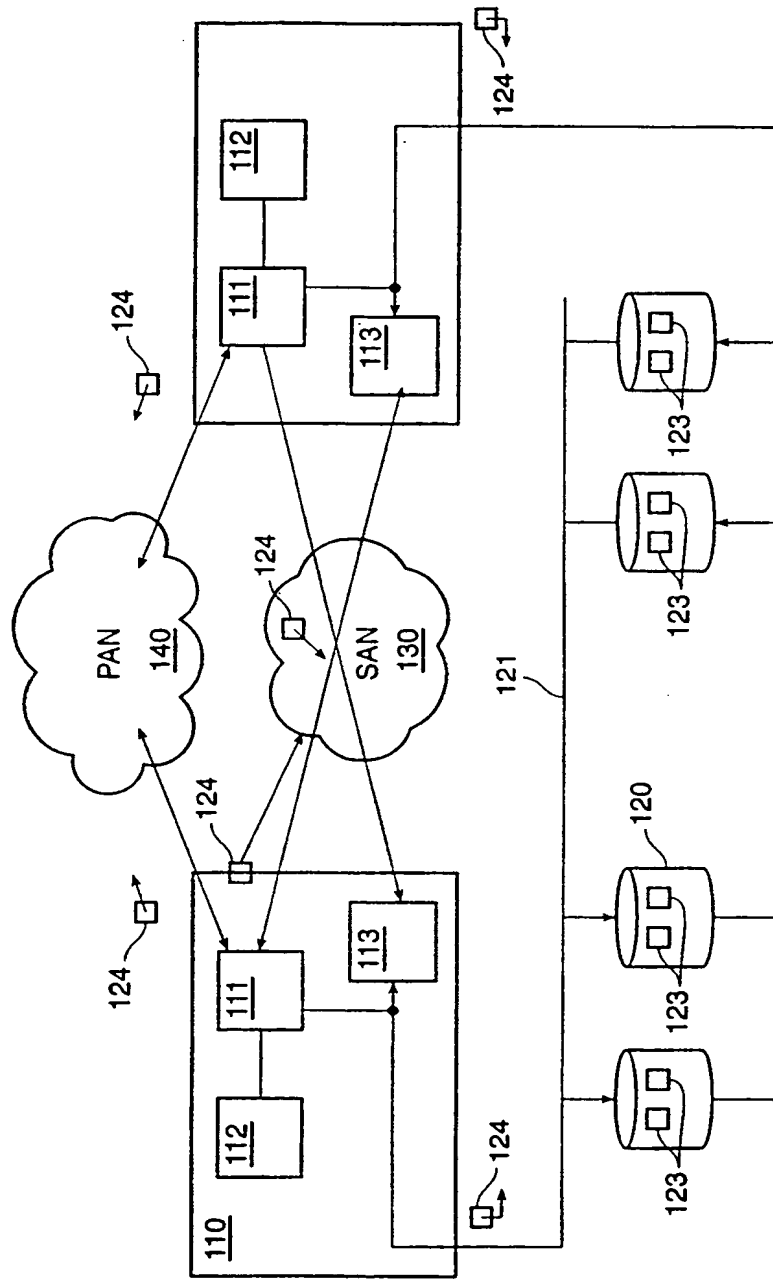

FIG. 1

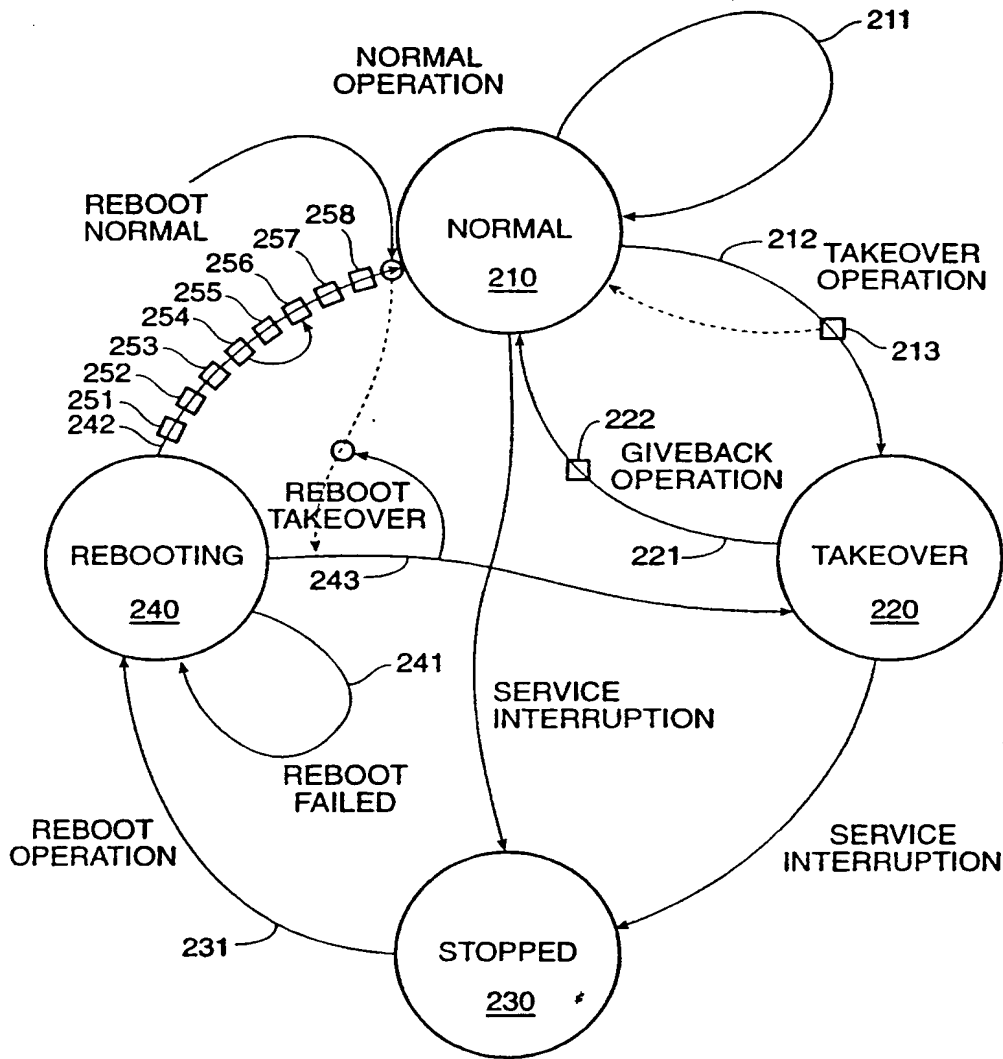

FIG. 2

**THIS PAGE BLANK (USPTO)**

# INTERNATIONAL SEARCH REPORT

International Application No  
PCT/US 99/17137

**A. CLASSIFICATION OF SUBJECT MATTER**  
IPC 7 G06F11/14

According to International Patent Classification (IPC) or to both national classification and IPC

**B. FIELDS SEARCHED**

Minimum documentation searched (classification system followed by classification symbols)  
IPC 7 G06F

Documentation searched other than minimum documentation to the extent that such documents are included in the fields searched

Electronic data base consulted during the international search (name of data base and, where practical, search terms used)

**C. DOCUMENTS CONSIDERED TO BE RELEVANT**

Category *	Citation of document, with indication, where appropriate, of the relevant passages	Relevant to claim No.
A	EP 0 306 244 A (DIGITAL EQUIPMENT CORPORATION) 8 March 1989 (1989-03-08) page 2, line 34 - line 43 ---	1-26
A	EP 0 308 056 A (INTERNATIONAL BUSINESS MACHINES) 22 March 1989 (1989-03-22) column 4, line 4 - line 16 ---	1-26
A	EP 0 760 503 A (COMPAQ COMPUTER CORPORATION) 5 March 1997 (1997-03-05) column 7, line 12 - line 35 -----	1-26

Further documents are listed in the continuation of box C.

Patent family members are listed in annex.

\* Special categories of cited documents :

- \*A\* document defining the general state of the art which is not considered to be of particular relevance
- \*E\* earlier document but published on or after the international filing date
- \*L\* document which may throw doubts on priority claim(s) or which is cited to establish the publication date of another citation or other special reason (as specified)
- \*O\* document referring to an oral disclosure, use, exhibition or other means
- \*P\* document published prior to the international filing date but later than the priority date claimed

- \*T\* later document published after the international filing date or priority date and not in conflict with the application but cited to understand the principle or theory underlying the invention
- \*X\* document of particular relevance; the claimed invention cannot be considered novel or cannot be considered to involve an inventive step when the document is taken alone
- \*Y\* document of particular relevance; the claimed invention cannot be considered to involve an inventive step when the document is combined with one or more other such documents, such combination being obvious to a person skilled in the art.
- \*Z\* document member of the same patent family

Date of the actual completion of the international search

Date of mailing of the international search report

9 November 1999

16/11/1999

Name and mailing address of the ISA

European Patent Office, P.B. 5818 Patentlaan 2  
NL - 2280 HV Rijswijk  
Tel. (+31-70) 340-2040, Tx. 31 651 epo nl,  
Fax: (+31-70) 340-3016

Authorized officer

Corremans, G

# INTERNATIONAL SEARCH REPORT

Information on patent family members

International Application No

PCT/US 99/17137

Patent document cited in search report	A	Publication date		Patent family member(s)	Publication date
EP 306244	A	08-03-1989		CA 1311849 A	22-12-1992
				DE 3854026 D	27-07-1995
				JP 2118872 A	07-05-1990
				JP 1152543 A	15-06-1989
				US 5099485 A	24-03-1992
EP 308056	A	22-03-1989		AU 2002988 A	02-03-1989
				CA 1299757 A	28-04-1992
				DE 3855673 D	02-01-1997
				DE 3855673 T	07-05-1997
				JP 1070855 A	16-03-1989
				JP 1870554 C	06-09-1994
				JP 5081942 B	16-11-1993
				US 4970640 A	13-11-1990
EP 760503	A	05-03-1997		US 5696895 A	09-12-1997
				US 5781716 A	14-07-1998